



# SPECIFICATION SHEET

# GARGOYLE HATCH GUARDRAIL

The Gargoyle Hatch Guardrail System provides essential fall protection for rooftop hatch openings. Made in the USA from high-strength aluminum, Hatch Guardrail meets and exceeds OSHA and ANSI safety standards. Available in convenient kit formats, this system features a self-closing gate and modular design that fits most rooftop hatches. The non-penetrating design ensures easy installation without compromising roof integrity, keeping workers safe during entry and exit.

---

## FEATURES

- Modular Design:** Easily assembled and reconfigured for various rooftop layouts.
- Non-Penetrating:** No drilling, welding, or bolting required.
- Counter-Weighted:** Baseplates provide stability without damaging the roof.
- Compliance:** Meets or exceeds OSHA, ANSI, and state-specific safety standards.
- Durable Materials:** High-strength aluminum construction

# GARGOYLE ROOFTOP GUARDRAIL

Freestanding counterweighted rooftop guardrail system.

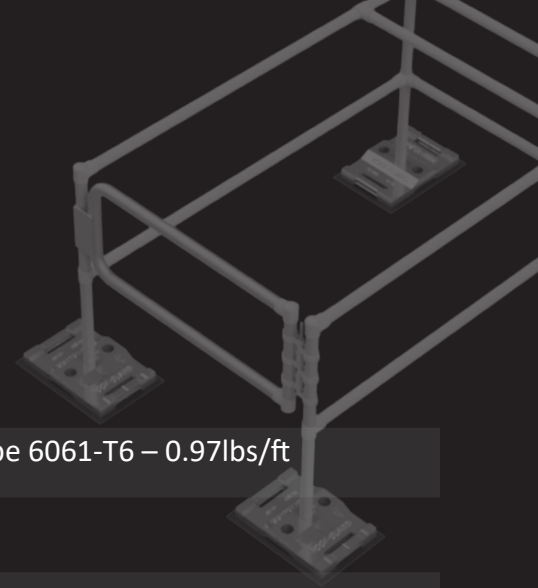

## SPECIFICATIONS

### Material & Dimensions

Guardrail	Ø1-1/2" (Ø1.9 OD) Schedule 40 Aluminum Pipe 6061-T6 – 0.97lbs/ft
Fittings	Ø1-1/2" (Ø1.9 OD) Aluminum Magnesium
Hardware	All stainless steel
End Caps	Plastic inserts
Baseplates	Galvanized Steel – 40lbs/ea
Rubber Pad	14" x 20" x .125" Masticated Rubber
Finish	Mill finished (standard); powder coating available

### Dimensions

Rail Height	42" from ground to top rail
Rail Diameter	1.9" OD Aluminum Pipe
Compliance	Meets/exceeds CAL/WA OSHA, OSHA, & ANSI standards
Product Warranty	2 years
Custom	Egress handles are available as an add on.

### Kit Options

Kit Size	Part Number	Height	Coverage	Rail Diameter	Weight
4' x 4'	HG-KIT-08	42"	16 square feet	1.9" OD Aluminum	450 lbs
4' x 6'	HG-KIT-4X6	42"	24 square feet	1.9" OD Aluminum	500 lbs
6' x 6'	HG-KIT-6X6	42"	36 square feet	1.9" OD Aluminum	550 lbs
4' x 8'	HG-KIT-4X8	42"	32 square feet	1.9" OD Aluminum	500 lbs
4' x 10'	HG-KIT-4X10	42"	40 square feet	1.9" OD Aluminum	600 lbs

